

SUTCO® BIOLOGICAL TREATMENT SYSTEMS.

**BIOLOGICAL AND RESIDUALS
PRESS WATER FERMENTATION
LOCATION: GESCHER, GERMANY**

**CONSERVING RESOURCES THROUGH
INNOVATIVE ENVIRONMENTAL TECHNOLOGY.**



COMBINED FERMATION PROCESSING BIOWASTE PRESS WATER FERMATION BIOPV GESCHER

PREPARATION PLANT FOR THE FERMENTATION OF THE EXTRACTED LIQUID PHASE FROM BIO-WASTE IN BIOFILM REACTORS FOR THE OBTAINMENT OF BIOGAS AND COMPOST.

CUSTOMER:

Entsorgungsgesellschaft Westmünsterland mbH
(EGW) Gescher, Germany

LEADTIME:

2012 - 2014

INVESTOR / OPERATOR:

Entsorgungsgesellschaft Westmünsterland mbH
(EGW) Gescher, Germany

THROUGHPUT:

60.000 Mg/a

SCOPE OF WORK:

Development and conception of an alternative fermentation process to improve the energy balance and processing capacity of composting plants. Construction, production, completion, installation and commissioning after trial operation.

ORGANIC WASTE-PRESS WATER DIGESTION

Sutco Recycling Technik GmbH has developed a new digestion technology BioPV (organic waste press water digestion) as an alternative digestion process which significantly improves the energy balance and the processing capacity of composting plants.

Sutco Recycling Technik GmbH succeeded in achieving a maximum gas yield from the liquid phase pressed out organic waste with lowest technical efforts during the development of their new digestion process BioPV. With this technology organic ingredients are pressed out from the biowaste as a liquid phase and digested in biofilm reactors for generating biogas.

Up to now, mainly dry digestion are state of the art

for the energetic use of the organic substances contained in household waste. However, these processes achieve a high biogas yield but require considerable efforts and expenses for the treatment of the digestion rest to provide a quality-based compost. The conditioning and drying of the digestion rest requires a high energy consumption for that.

Contrary to that, Sutco could largely avoid digestion rests to be disposed of externally with their BioPV. Here, digestion is performed in parallel to the composting process with the liquid phase squeezed out from fresh organic waste. The digestion rest is run in a cycle and is only disposed of in case of excess water in the total plant.



THE BIOPV (ORGANIC WASTE PRESS WATER DIGESTION), THE BIOLOGICAL WASTE TREATMENT PROCESSES CAN BE CLASSIFIED AS FOLLOWS:

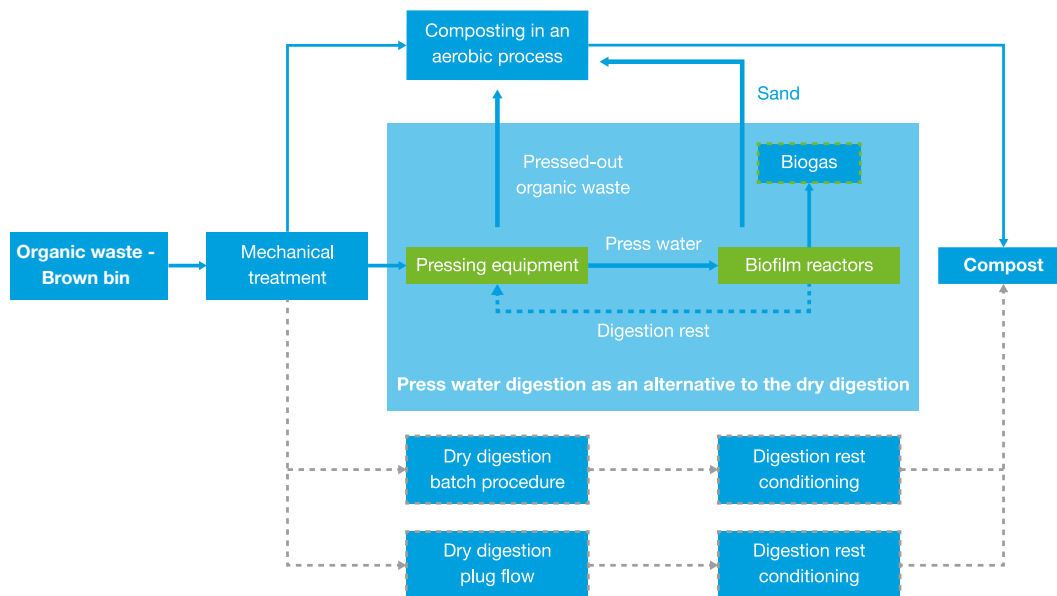

HIGHLY EFFICIENT ENERGY PRODUCTION PLUS QUALITY COMPOST

The wet digestion of a suspension obtained from organic waste can be implemented with significantly lower efforts and expenses than the alternative dry digestion of organic waste as a solid material - this is the result from the knowledge obtained from the large-scale operation of the composting and digestion plant of the the Entsorgungsgesellschaft Westmünsterland (EGW). Due to the high time-space charge (dwell time in the digestion process of 8 to 10 days) the wet digestion in fixed-bed digester additionally provides a highly efficient production of energy.

The robust and long experienced aerobic treatment

process is retained for pressed-out solid waste, with the advantage that the input material is freed from parts of organic matter. Furthermore through the pressing process the solid material is homogeneously wetted and inoculated for an optimal start of the aerobic process. The expensive and difficult conditioning required for a further use of the digestion rests from the digesters of the dry digestion plants is not required for the BioPV.

One ton of organic waste yields 0.7 to 0.8 tons of press water. The digestion plant depending on input waste generates 50 to 90 m³/t of biogas with a methane content of 60 to 70 % from that.

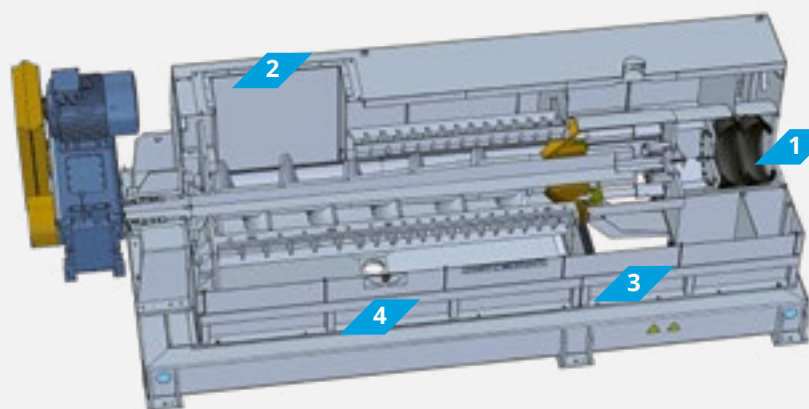

- 1 Pneumatic bellow cylinder: 2-5 bar
- 2 Charge of organic waste
- 3 Press cake exit
- 4 Liquid phase exit

Screw press of the Bellmer-Kufferath company for compacting biowaste

BiOPV PRESSING EQUIPMENT

In the treatment plant the pressing equipment is installed in the pre-treatment equipment before the solid waste which is crushed and screened to < 80 mm is charged. Two presses installed in parallel and alternating continuously are fed via reversing conveyor belt. Due to the low pressing pressures with low energy consumption and wear, the structure of the waste for aeration in composting is not destroyed. .

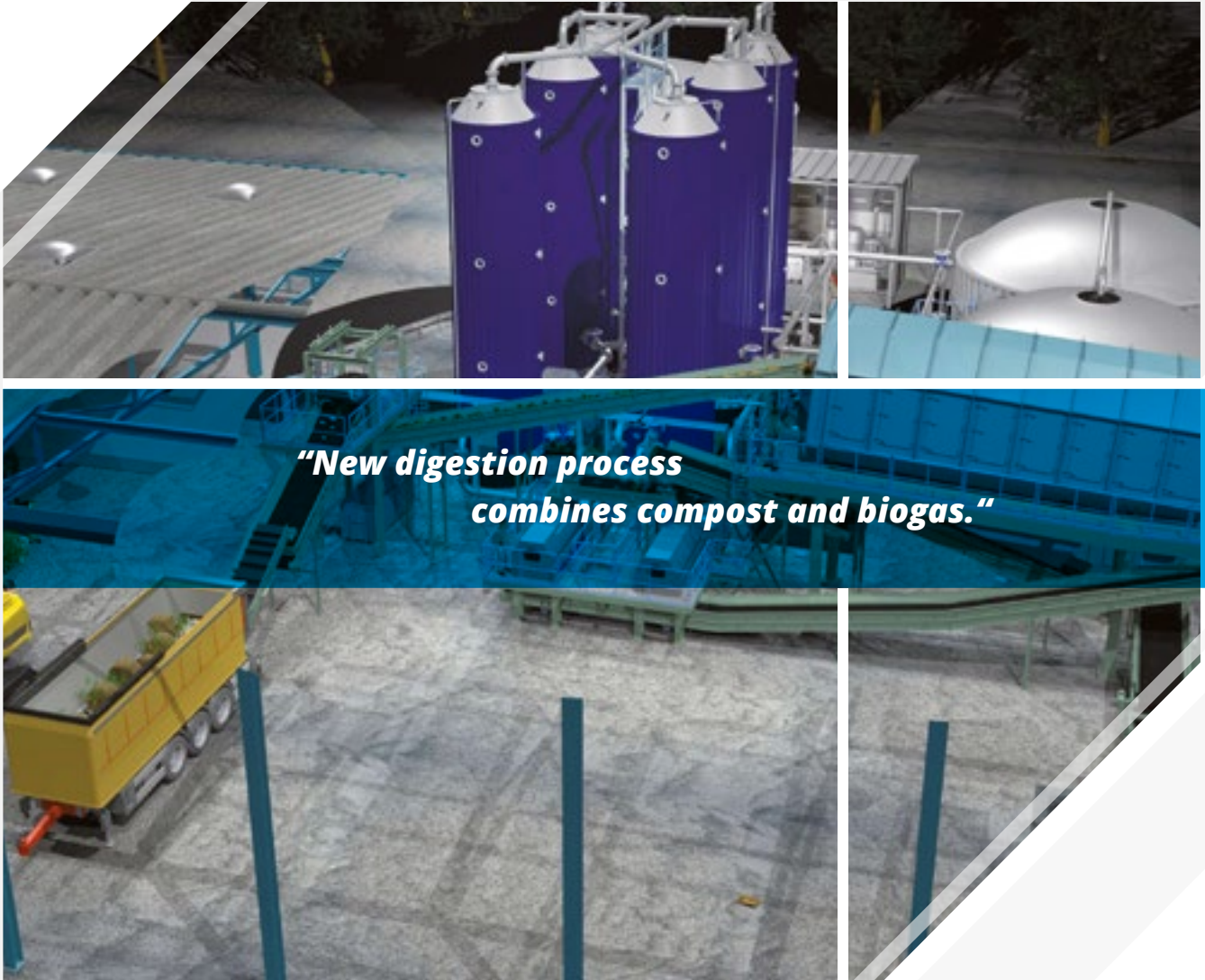

**“New digestion process
combines compost and biogas.”**

**AS A RESULT, THE EFFICIENCY OF THIS DIGESTION PLANT
CAN BE REPRESENTED AS FOLLOWS:**

ORGANIC WASTE [Mg]	PRESS WATER VOLUME PRODUCED [m ³]	DWELL TIME DIGESTION PLANT [d]	BIOGAS [m ³] FOR EACH Mg OF PRESS WATER	BIOGAS [m ³] FOR EACH MG OF ORGANIC
100 + 75	75	8 - 10	55	42
PRESSING EQUIPMENT FOR ORGANIC WASTE AND THE DIGESTION OF PRESS WATER		QUANTITIES		PROFITABILITY
Estimated investment costs		60,000 Mg of organic waste/a		~3.200.000 €
Estimated wearing and operating costs		Incl. presses and BHPP		~200.000 €/a
Estimated energy consumption		~190.000 kWh/a		~30.000 €/a
Biogas produced and energy production in CHP unit		2.500.000 m ³ /a -> 7.000.000 kWh _{el} /a		~980.000 €/a (base EEG 2016)
Revenues of each ton of digestion input		15.000 – 30.000 Mg/a		2 to 5 €/Mg

Information provided without guarantee

OVERVIEW OF THE ADVANTAGES

- Fermentation of a highly energetic liquid phase, recovered from the solid waste in the bypas to the composting process
- Removal of easily available organic material from the solid waste: to facilitate the aerobic treatment
- Simple fermentation system of modular design with low investment costs
- High throughputs and low dwell times in a fixed-bed fermenter with a fixed bacterial colonisation
- Very high methane content of 60 - 70% and thus a high energy content in the biogas
- Circulation of the fermentation residue for wetting the fresh biowaste; no waste water to be disposed of externally
- Low-wear plant equipment which is easy to operate and maintain
- Automatic sand separation in the current fermentation process
- Hygienization by thermophile and continuous fermenter flow possible

- 
- The EGW digestion plant with a fixed-bed digester for organic waste press water produces biogas which is used as biomethane or is converted to electrical and thermally useful energy via a biogas motor.

ENERGY GAIN

HIGH THROUGH-PUT IN THE FIXED BED

SUTCO®. NEW FERMENTATION TECHNOLOGY

NO POST-COMPOSTING OF THE FERMENTATION RESIDUES



THE EFFICIENCY OF THE FERMENTATION PLANT FOR **RESIDUAL WASTE** IS AS FOLLOWS:

RESIDUAL WASTE < 80 MM + WATER [Mg]	PRESS WATER VOLUME PRODUCED [m ³]	DWELL TIME DIGESTION PLANT [d]	BIOGAS [m ³] FOR EACH TON OF PRESS WATER	BIOGAS [m ³] FOR EACH TON OF ORGANIC
100 + 60	60	8 - 10	90	54

PRESSING EQUIPMENT FOR RESIDUAL WASTE AND THE DIGESTION OF PRESS WATER	QUANTITIES	PROFITABILITY
Estimated investment costs	60.000 Mg of residual waste < 80mm/a	~3.500.000 €
Estimated wearing and operating costs	Incl. presses and BHPP	~200.000 €/a
Estimated energy consumption	~190.000 kWh/a	~30.000 €/a
Estimated energy generation with a CH ₄ content of 60% in a CHP plant	3.240.000 m ³ /a -> 9.200.000 kWh _{el} /a	~100.000 €/a (0,12 €/kWh _{el})

Information provided without guarantee



Sutco® RecyclingTechnik GmbH

Paffrather Str. 102-116, 51465 Bergisch Gladbach, Germany

Telefon +49 2202 2005 01

Web www.sutco.com

E-Mail info@sutco.de

WE GET THE BEST OUT.

Supported by:



Federal Ministry
for Economic Affairs
and Energy

on the basis of a decision
by the German Bundestag

